

**Bedienungsanleitung
und
Sicherheitsbestimmungen
für
RAHMENHAKEN,
KETTEN UND
KETTENHALTER**





JOSAM

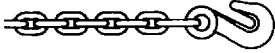
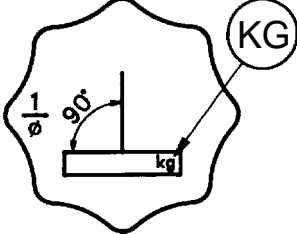

JOSAM frame press

Kettentyp und Beschreibung

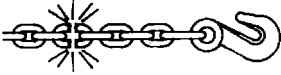
KETTE DIN 5687 KLASSE 8 	BEACHTEN SIE DIE MARKE FÜR MAX. ZUGELASSENE TRAGFÄHIGKEIT 	MAX. ZUGELASSENE TRAGFÄHIGKEIT BEIM RICHTEN VON NUTZFAHRZEUGEN  JOSAM	BRUCHKRAFT 
SYMBOL			
KL8-8-3M	2000 (2 to)	40kN (4 to)	80kN (8 to)
KL11-8-3M	3000 (3 to)	75kN (7.5 to)	150kN (15 to)
KL11-8-8M	3000 (3 to)	75kN (7.5 to)	150kN (15 to)
KL13-8-3M	5000 (5 to)	100kN (10 to)	210kN (21 to)
KL16-8-3M	8000 (8 to)	150kN (15 to)	320kN (32 to)
KL19-8-3M	11000 (11 to)	200kN (20 to)	450kN (45 to)

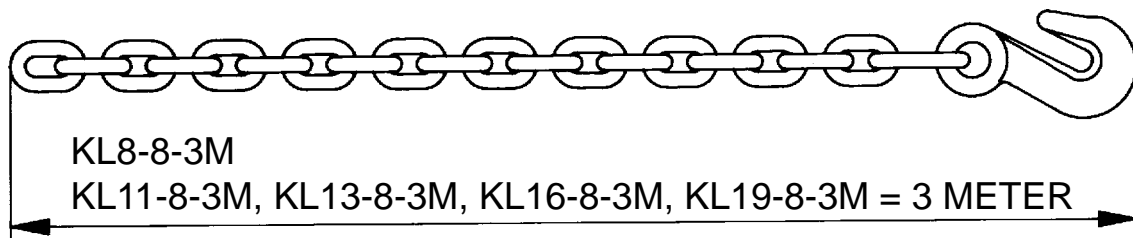

KL11-8-8M = 8 METER

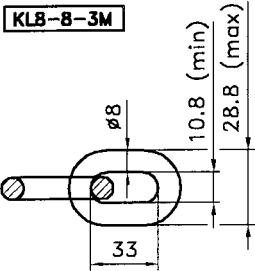
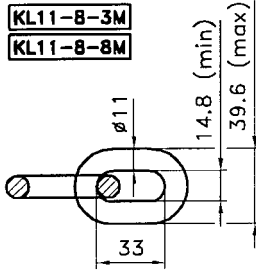
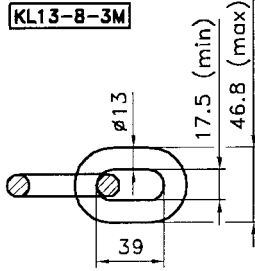
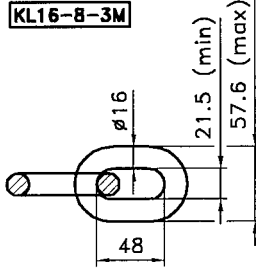
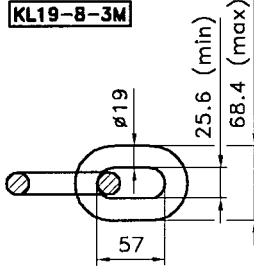
KL8-8-3M	KL11-8-3M KL11-8-8M	KL13-8-3M	KL16-8-3M	KL19-8-3M
				



MAXIMAL ZULÄSSIG ABWEICHEN DER KETTENGLIEDLÄNGE

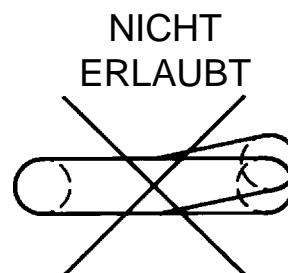
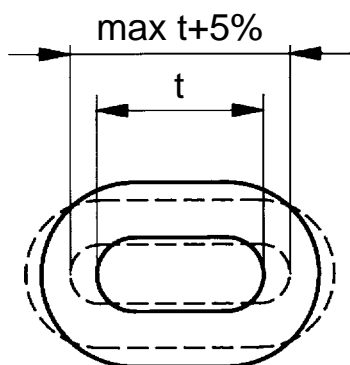

**MAX. ZULÄSSIGE LÄNGE
GEMESSEN ÜBER 5 KETTENGLIEDER**

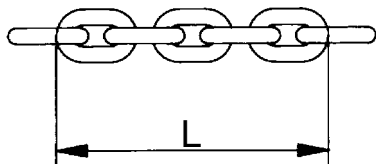

KÄTTING TYP	L (mm)
KL 8-8	143
KL 11-8	196
KL 13-8	232
KL 16-8	285
KL 19-8	339

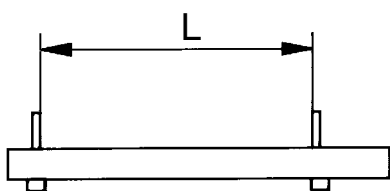

**PRÜFVORRICHTUNG ZUM
ÜBERPRÜFEN VON KETTEN**



**BENUTZEN SIE KEINE GEDEHNTEN
KETTEN, DIE ÜBER DEN ZULÄSSIGEN
TOLERANZEN LIEGEN.**



ZUGARM UNIVERSAL AUS ALUMINIUM JO 1500 K

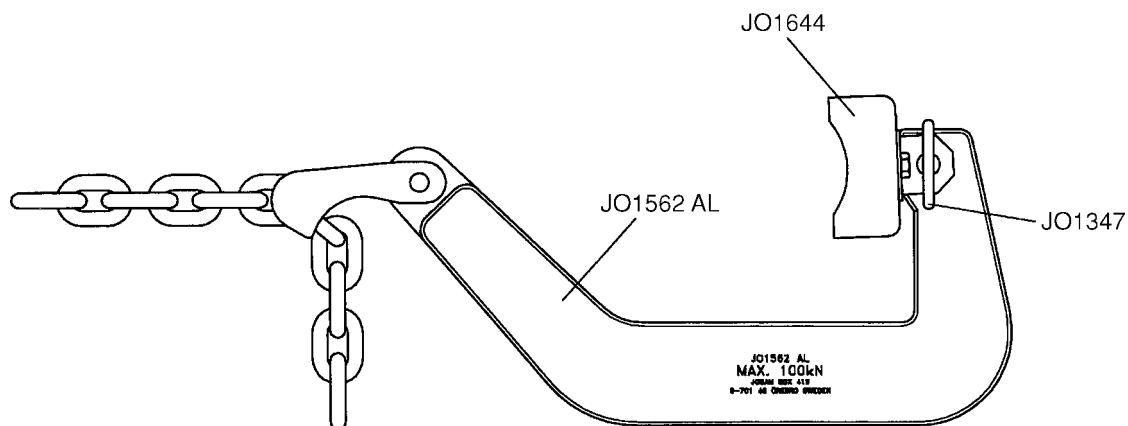

KETTE KL11-8-3M, KL11-8-8M
alternativ KL13-8-3M werden
verwendet in Kombination mit dem
Universal-Zugarm JO 1500 K.

**RAHMENHAKEN JO1294 AL MIT
FLANSCHVERSTÄRKUNG SR293 AL**

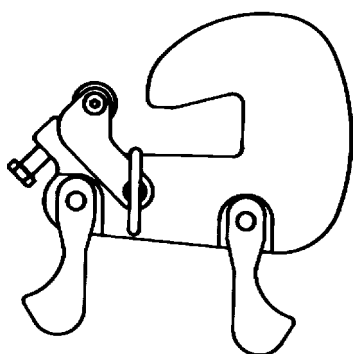

JO1294 AL

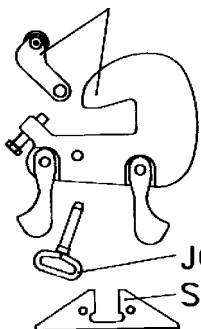

JO1347
SR293 AL

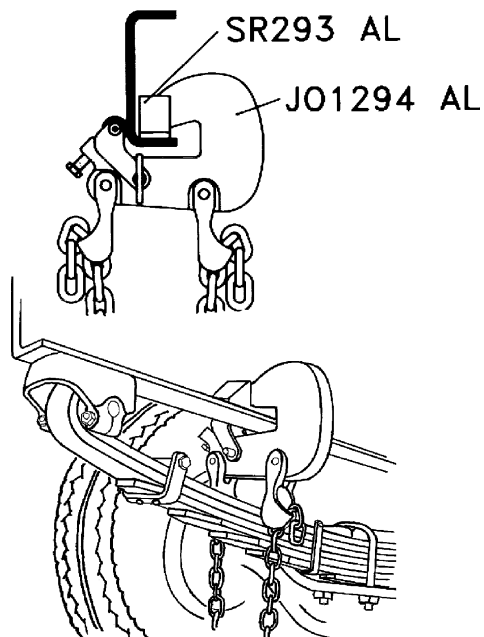

Benutzen Sie für Rahmenhaken
JO1294 AL AUSSCHLIEßLICH
DIE KETTE KL13-8-3M.



RAHMENHAKEN FÜR SATTELAUFLIEGER JO 2130 K

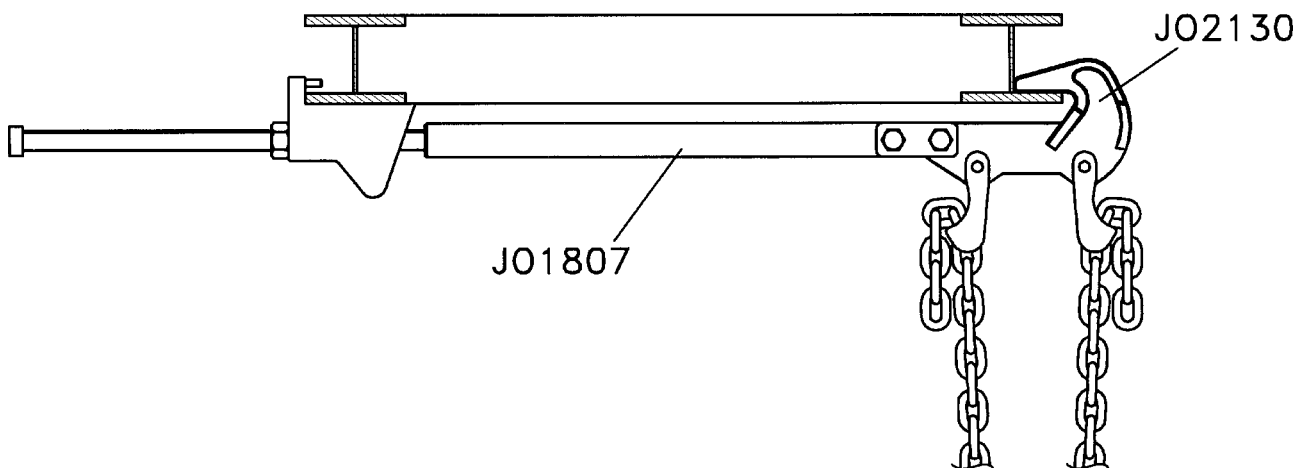

Benutzen Sie für Rahmenhakensatz
JO 2130 K **AUSSCHLIEßLICH**
DIE KETTEN KL11-8-3M.



Benutzen Sie für Rahmenhakensatz
JO 2130 K **AUSSCHLIEßLICH**
DIE KETTE KL11-8-3M.

**RAHMENHAKEN FÜR I-RAHMEN
JO2030 AL MIT
FLANSCHVERSTÄRKUNG
SR88 AL**

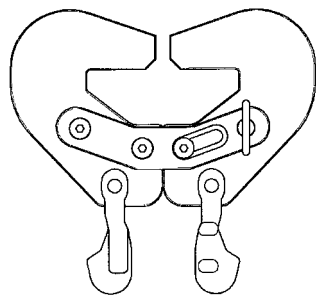

JO2030 AL

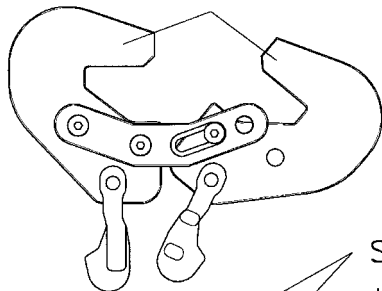

SR88 AL
JO2031

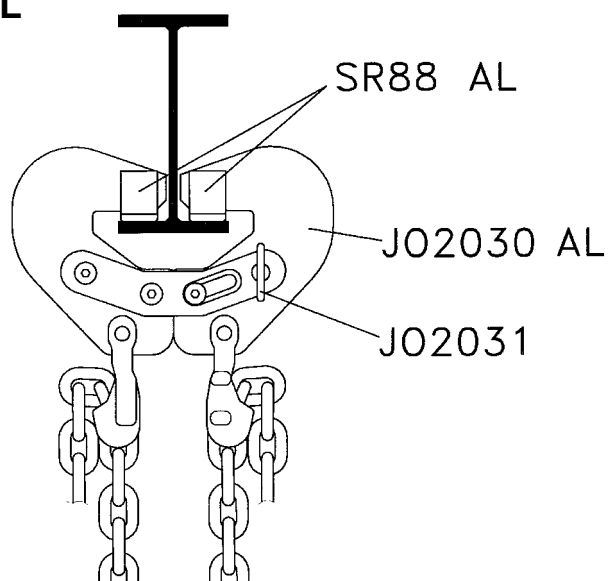
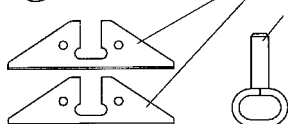

KETTE KL13-8-3M alternativ
KL16-8-3M werden verwendet in
Kombination mit den Rahmenhaken
JO2030 AL.



KETTENHALTER JO44 A

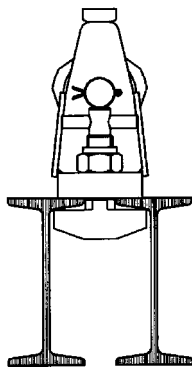
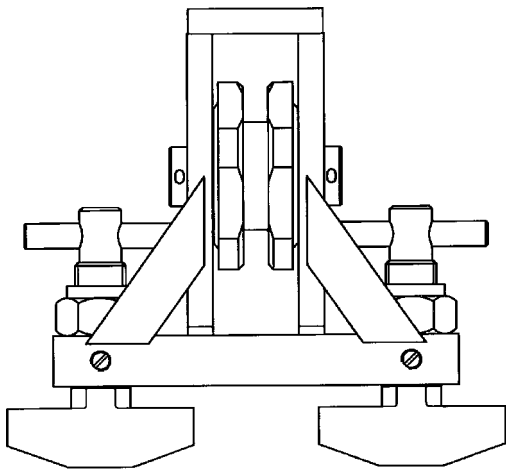

**MAX
200 kN
(20 to)**

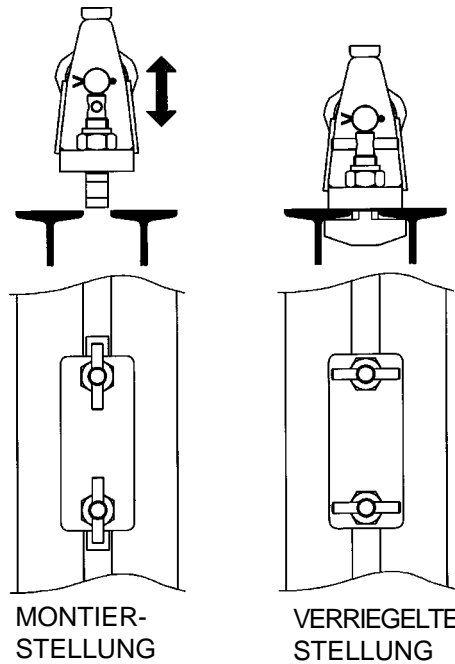

Die Verankerungsplatten müssen bei VERRIEGELTER STELLUNG RECHTWINKELIG zum Schlitz im Fundamentrahmen stehen.

JO47 B
JO1933
JO1934

KETTENHALTER JO47 B

M30x80 8.8
SR97

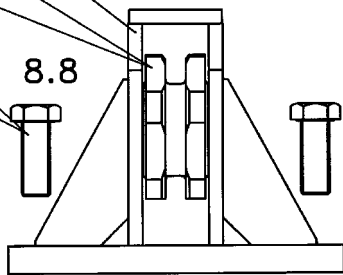

SR4-1

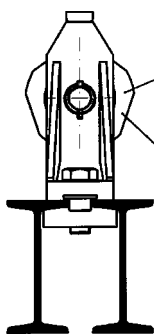

**JO1933
MAX
300 kN
(30 to)**

**JO1934
MAX
400 kN
(40 to)**

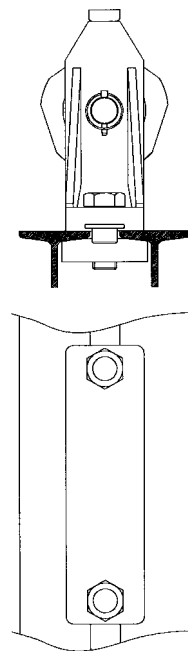

WICHTIG: Ziehen Sie die beiden BOLZEN SR97 FEST AN.



ZUGARM UNIVERSAL AUS ALUMINIUM JO 1500 K

KETTE KL11-8-3M, -8M

**MAX
75 kN
(7,5 to)**

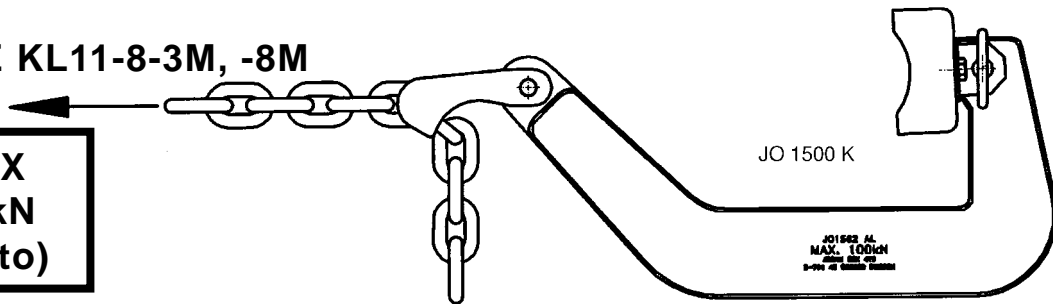

KETTE KL13-8-3M

**MAX
100 kN
(10 to)**

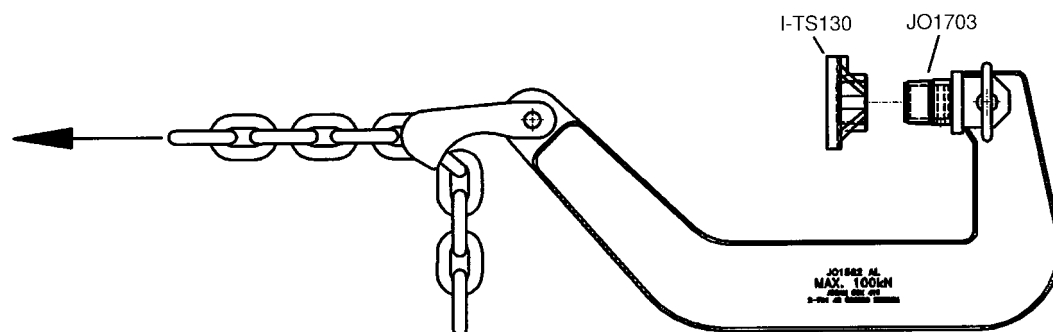
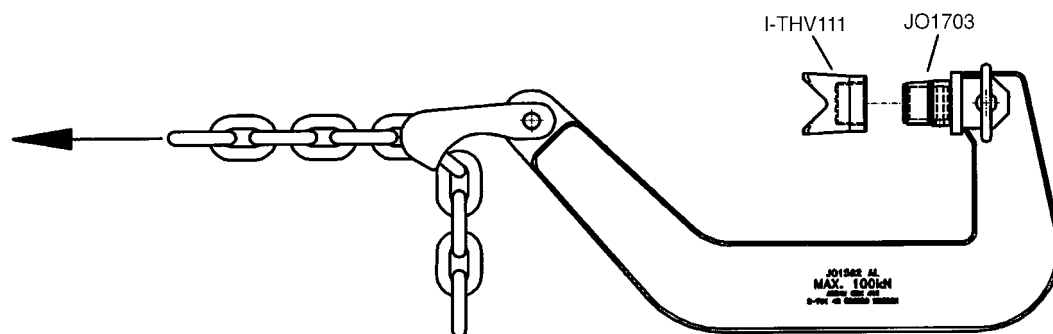
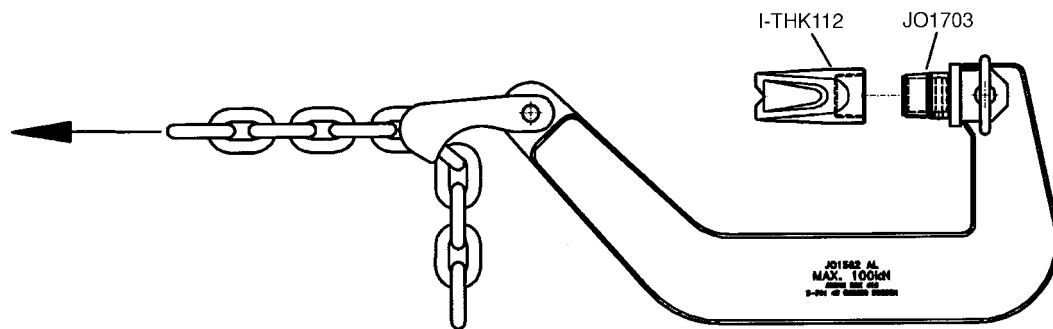
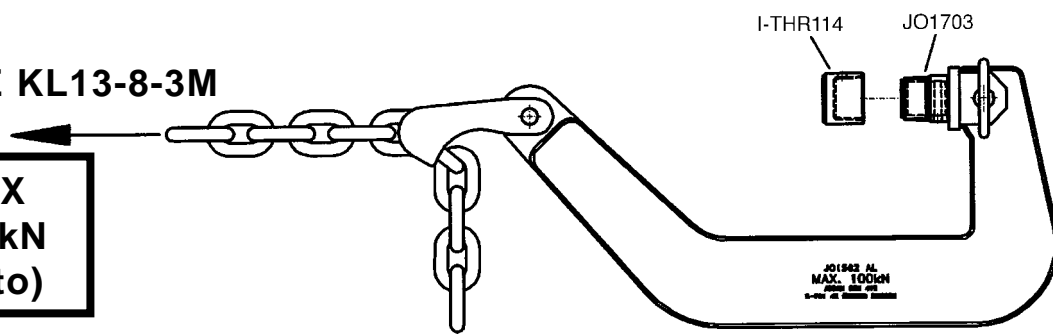



**KETTENHALTER JO44 A - KETTE KL13-8-3M
RAHMENHAKEN JO1294 AL, JO2030 AL UND JO 2130 K**

KETTE KL13-8-3M

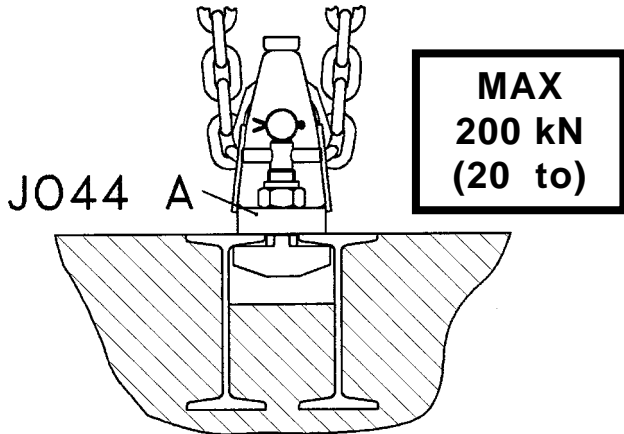

 Benutzen Sie NIE die Ketten KL16-8-3M mit dem Kettenhalter JO44 A.

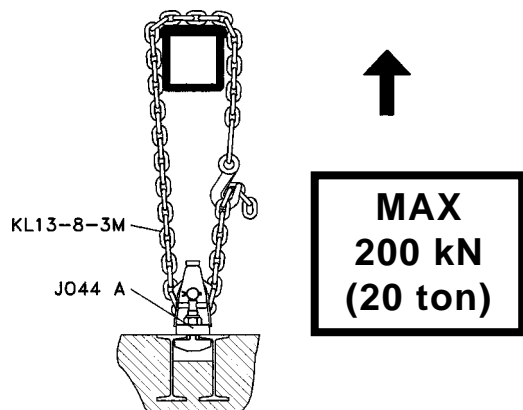
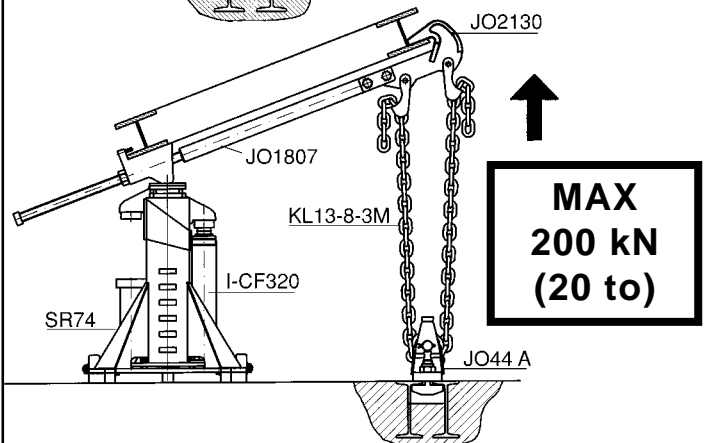
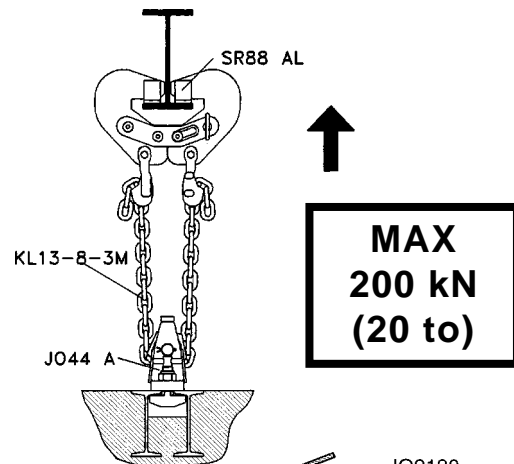
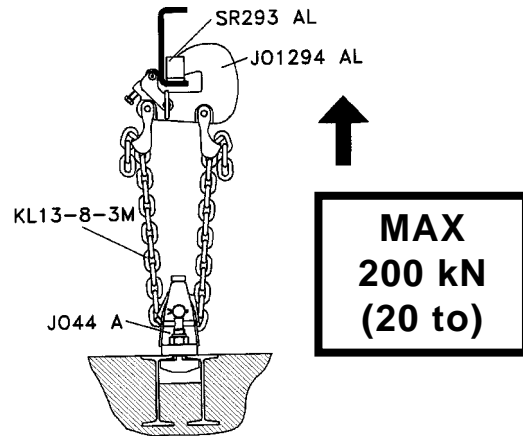



**RAHMENHAKENSATZ JO 2130 K FÜR SATTELAUFLIEGER IN KOMBINATION
MIT 20 TON HYDRAULISCHE VERTIKALPRESSE SR74**

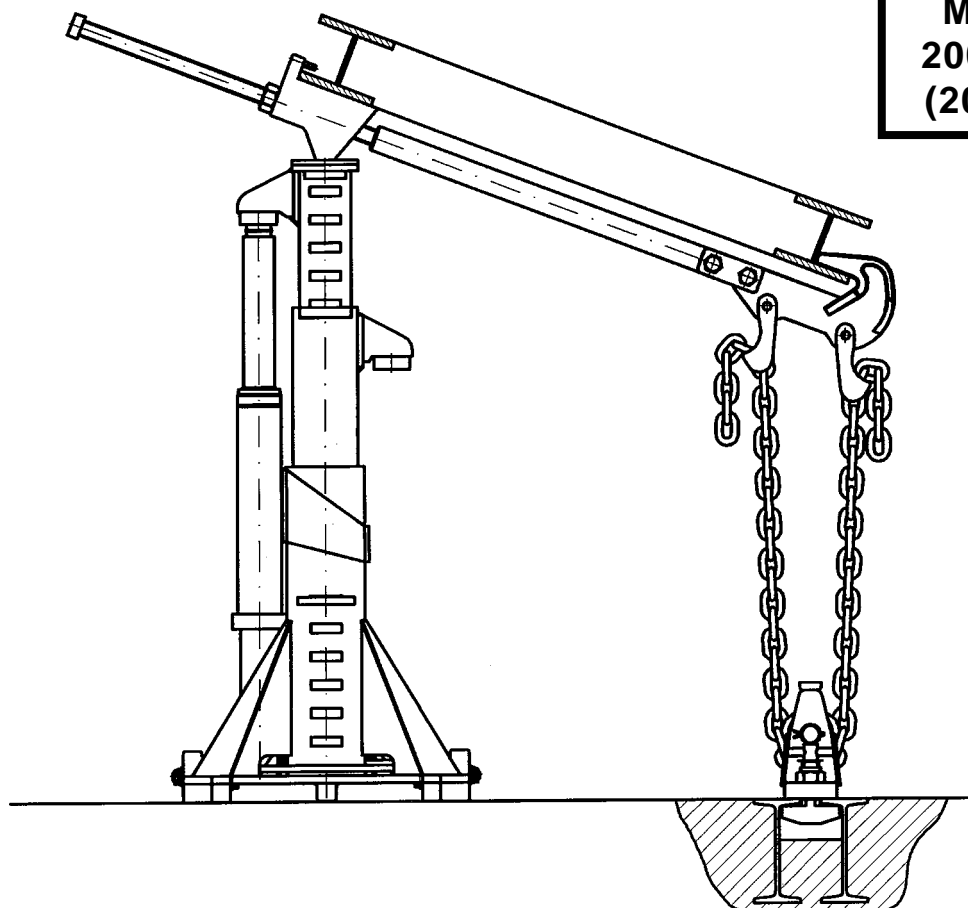
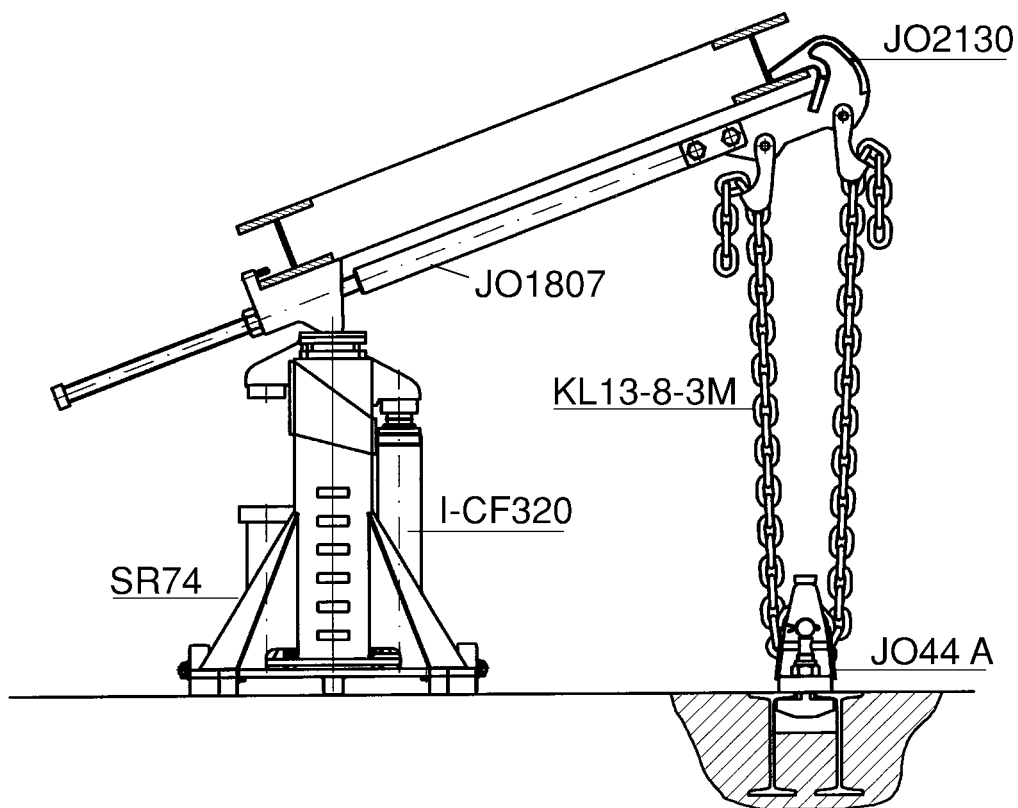

**MAX
200 kN
(20 to)**



**KETTENHALTER JO47 B - KETTE KL16-8-3M
RAHMENHAKEN JO2030 AL**

KETTE KL16-8-3M

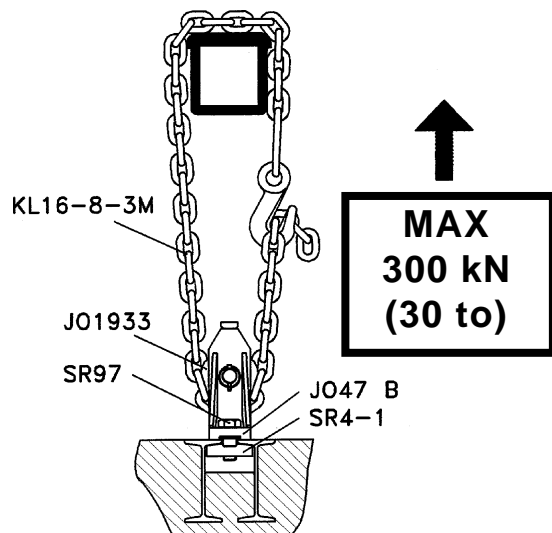
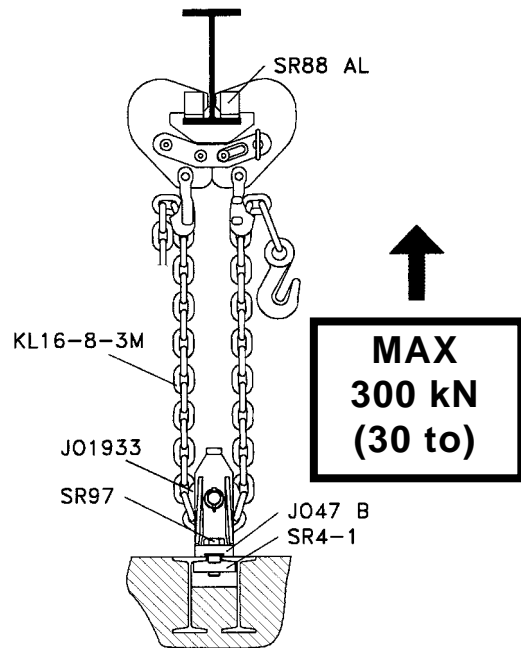
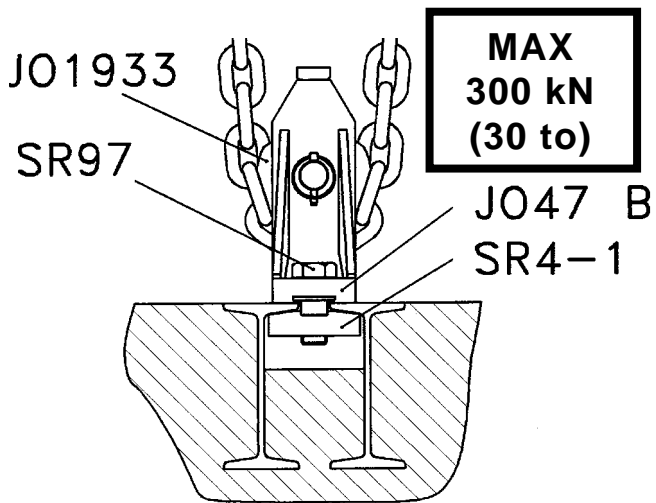



KETTENHALTER JO47 B - KETTE KL19-8-3M

KETTE KL19-8-3M

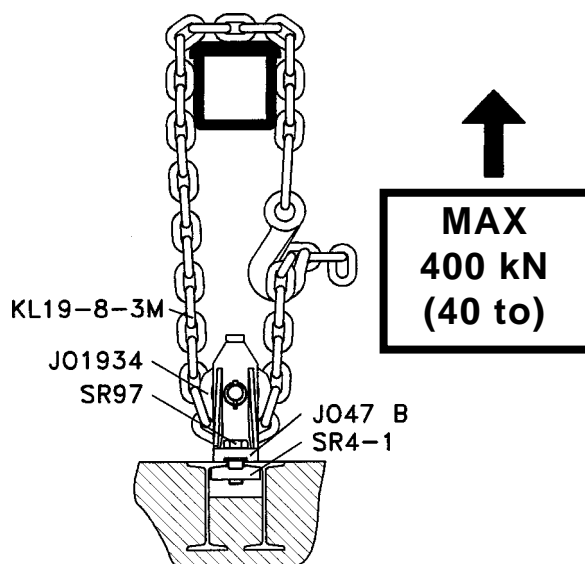
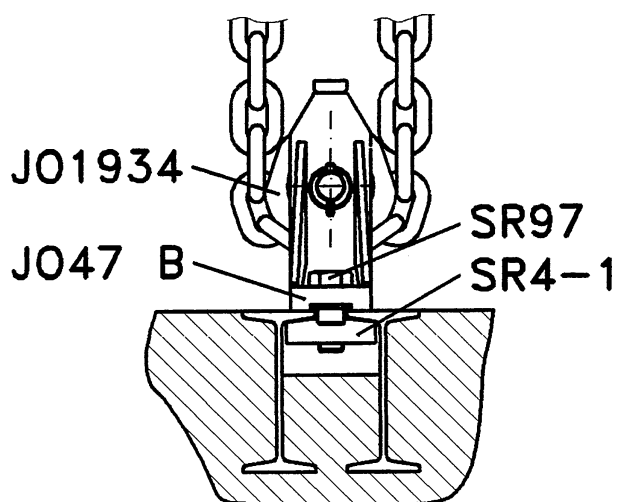

KETTE KL16-8-3M

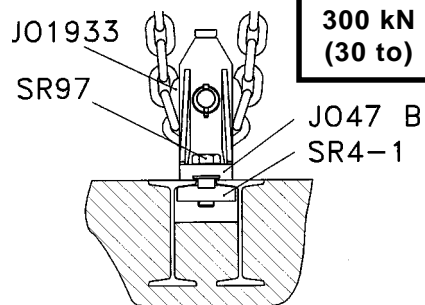

Hersteller:

JOSAM lastbilteknik ab

P.O.B 419 • 701 48 • ÖREBRO, Schweden

Tel: +46 19 30 40 00 • Fax: +46 19 32 03 16

E-mail: info@josam.se • Internet: www.josam.se



Gedruckt auf umweltfreundlichen Papier